

Versatility Team 2

CARO SPRING Virtual Trial

T24-001 May 11-24, 2024

Indoor/Outdoor 30' x 30'

Max Course Time: 3 minutes

Team One

1. Start – Dog on Right (R)
2. Call Front – Forward Left (433) (R)
3. Side by Side Left (403)
4. Slow Pace (118) (L)
5. Normal Pace (120) (L)
6. **Halt** – Turn Right – 1 Step – Halt (109) (L)
7. Cross Behind (405)
8. 180 Left (422) (R)
9. **Halt** – Sidestep Left – Halt (415)(R)
10. **Halt** – Walk Around (412) (R)

Team Two

11. Weave Poles (442) (R)
12. Turn In (400)
13. 360 Left (117) (L)
14. Call Front – Forward Left (124)(L)
15. **Halt** – 90 Degree Pivot Left – Halt (108)(L)
16. Weave Through Legs (406)
17. 180 Left (422)(R)
18. **Halt** – Down – Sit (411) (R)
19. Call Front – Return to Heel (434)(R)
20. Finish (R)

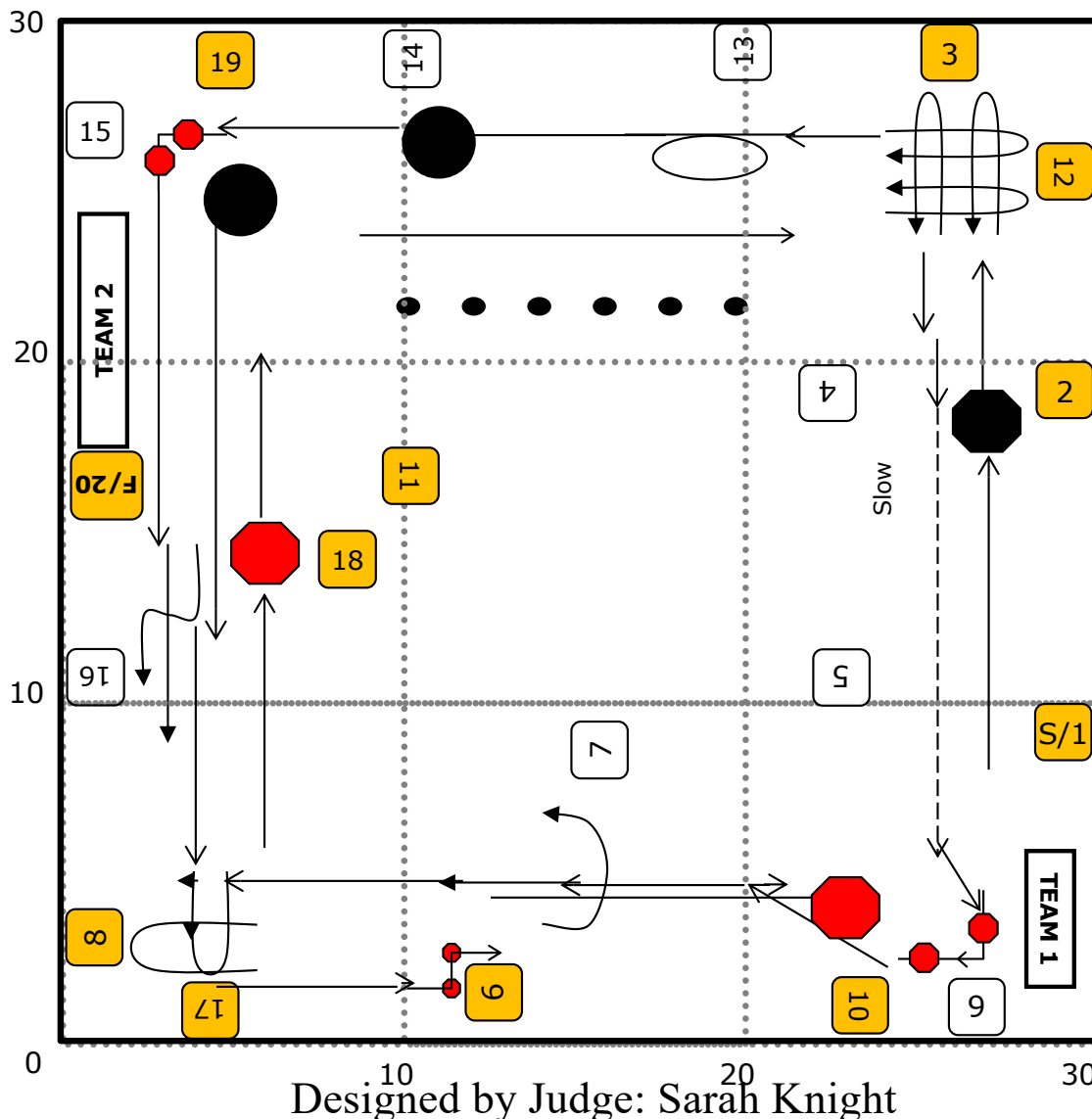

Please note Versatility Team 2 is NESTED with Versatility Team 1 to help make things easier for you as a competitor 😊



Camera must be placed along this side of the ring